

ACME SCREWS & NUTS

9 Inch (9.00 Inch) - Right Hand

Duff-Norton offers complete close mounted systems to complement these screw & nut assemblies as follows:

- Screw Journal Ends - Page 64
- End Blocks - Page 66
- Motor Flanges - Page 70
- Gearmotors - Page 76
- Controls - Page 96

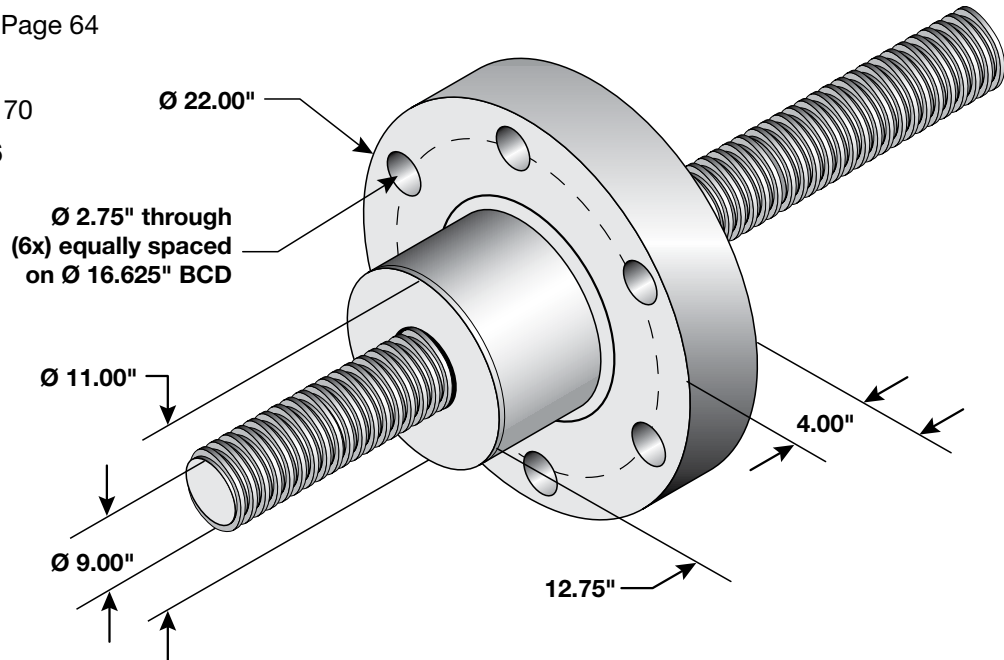

Acme Screw	Screw Diameter	Lead	Pitch	No. Starts	Root Diameter	Thread Form	Material	Max. Backlash	36"	Standard Lengths		
900ASA100	9.00	1.00	1.00	1	7.850	Mod Sq RH	Steel	.008	Yes	Yes	Yes	144"
Acme Nut	*Static Load	*Dynamic Load	*Max Speed	T.P.I.	Efficiency	Torque to Raise 1 Lb.	Material	Mounting Thread	Flange Width	Nut Length	Nut Diameter	
900ANB100	952,842	622,745	1725.00	1.00	23%	0.700	Bronze	Integral Flange	4.0	12.75	11.00	
Flange	Overall Diameter	Bolt Cir. Diameter	Bolt Hole Diameter	Mounting Holes	Flange Width	Treated	Material	Mounting Thread				
Integral	22.00	16.625	2.75	6	4	NA	Bronze	Integral Flange				

Note: Unless otherwise specified, all capacities are in Pounds, all dimensions are in Inches, and all speeds are in Inches per Minute.

*Load ratings are based on what the screw & nut assembly is capable of achieving. Actual load performance for a given screw and nut assembly will vary from application to application.

*Speed ratings are based on a directly coupled screw & motor turning at 1725 rpm. Actual speeds for a given screw and nut assembly will vary from application to application.

In many cases Duff-Norton can provide screw materials such as 316SS, longer screw lengths, or thread directions other than what has been cataloged.

Please contact our customer service department for assistance.



1/2 inch to 1-1/2 inch
bronze and plastic nuts
available in select T.P.I