

ACME

SCREWS & NUTS

2 Inch (2.00 Inch) - Left Hand

Duff-Norton offers complete close mounted systems to complement these screw & nut assemblies as follows:

- Screw Journal Ends - Page 64
- End Blocks - Page 66
- Motor Flanges - Page 70
- Gearmotors - Page 76
- Controls - Page 96

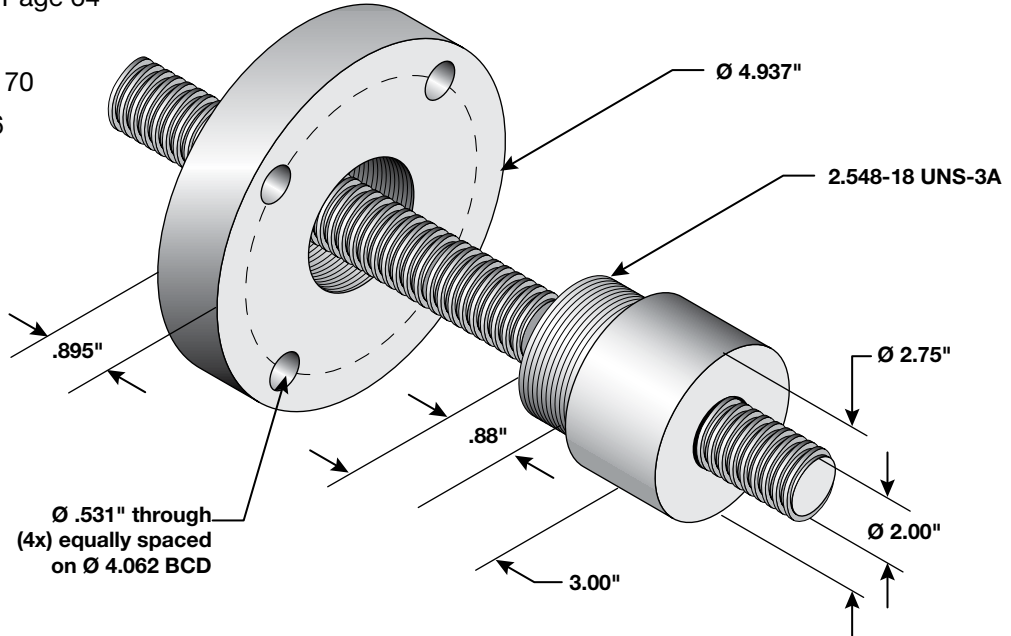

Acme Screw & Nut 2 Inch (2.00 Inch) Diameter - Left Hand

Acme Screw	Screw Dia.	Lead	Pitch	No. Starts	Root Dia.	Thread Form	Material	Maximum Backlash	Standard Lengths		
									36 Inch	72 Inch	144 Inch
200ASA025L	2.00	.250	.250	1	1.713	Centralizing LH	Steel	0.008	Yes	Yes	Yes
Acme Nut	*Static Load	*Dynamic Load	*Max. Speed	T.P.I.	Efficiency	Torque to Raise 1 Lb.	Material	Mounting Thread	Mounting Length	Nut Length	Nut Diameter
200ANB025L	94,877	31,034	431.25	4	24%	0.162	Bronze	2.548-18 UNF-3A	.88	3.00	2.75
Flange	Overall Dia.	Bolt Cir. Dia.	Bolt Hole Dia.	Mounting Holes	Flange Width	Treated	Material	Mounting Thread			
FL2548	4.94	4.062	.531	4	.895	Black Oxide	Steel	2.548-18 UNF-3A			

Note: Unless otherwise specified, all capacities are in Pounds, all dimensions are in Inches, and all speeds are in Inches per Minute.

*Load ratings are based on what the screw & nut assembly is capable of achieving. Actual load performance for a given screw and nut assembly will vary from application to application.

*Speed ratings are based on a directly coupled screw & motor turning at 1725 rpm. Actual speeds for a given screw and nut assembly will vary from application to application.

In many cases Duff-Norton can provide screw materials such as 316SS, longer screw lengths, or thread directions other than what has been cataloged.

Please contact our customer service department for assistance.



1/2 inch to 1-1/2 inch
brass and plastic nuts
available in select T.P.I

ACME SCREWS & NUTS

2 Inch (2.00 Inch) - Right Hand

Duff-Norton offers complete close mounted systems to complement these screw & nut assemblies as follows:

- Screw Journal Ends - Page 64
- End Blocks - Page 66
- Motor Flanges - Page 70
- Gearmotors - Page 76
- Controls - Page 96

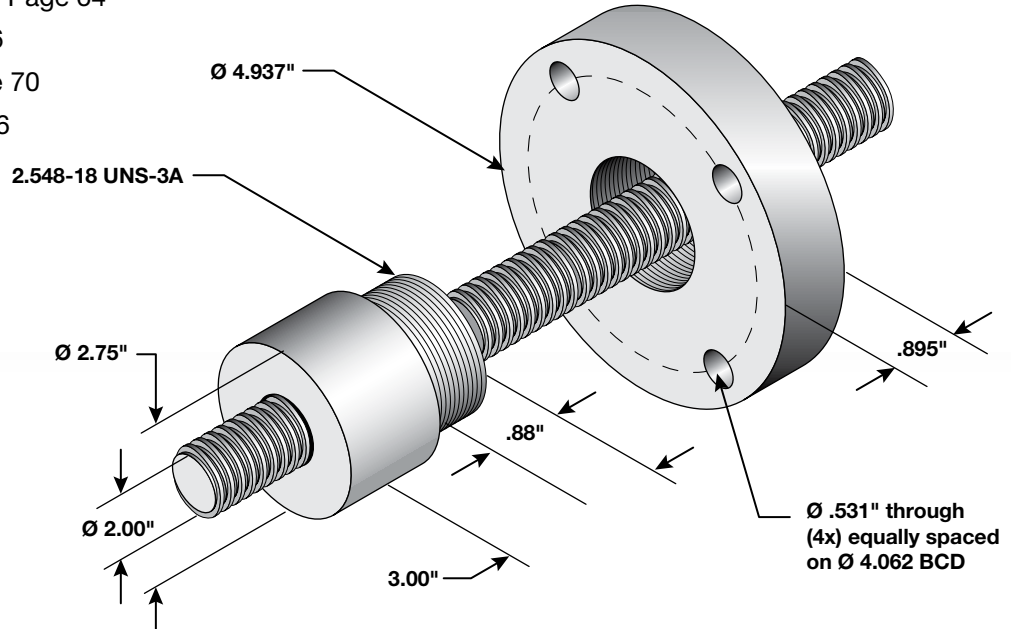

Acme Screw & Nut 2 Inch (2.00 Inch) Diameter - Right Hand

Acme Screw	Screw Dia.	Lead	Pitch	No. Starts	Root Dia.	Thread Form	Material	Maximum Backlash	Standard Lengths		
									36 Inch	72 Inch	144 Inch
200ASA025	2.00	.250	.250	1	1.713	Centralizing RH	Steel	0.008	Yes	Yes	Yes
200ASA050R		.500	.500		1.435			0.019			
Acme Nut	*Static Load	*Dynamic Load	*Max. Speed	T.P.I.	Efficiency	Torque to Raise 1 Lb.	Material	Mounting Thread	Mounting Length	Nut Length	Nut Diameter
200ANB025	94877	31034	431.25	4	24%	0.162	Bronze	2.548-18 UNF-3A	.88	3.00	2.75
200ANB050	94252	29352	862.50	2	40%	0.197					
Flange	Overall Dia.	Bolt Cir. Dia.	Bolt Hole Dia.	Mounting Holes	Flange Width	Treated	Material	Mounting Thread			
FL2548	4.94	4.062	.531	4	.895	Black Oxide	Steel	2.548-18 UNF-3B			

Note: Unless otherwise specified, all capacities are in Pounds, all dimensions are in Inches, and all speeds are in Inches per Minute.

*Load ratings are based on what the screw & nut assembly is capable of achieving. Actual load performance for a given screw and nut assembly will vary from application to application.

*Speed ratings are based on a directly coupled screw & motor turning at 1725 rpm. Actual speeds for a given screw and nut assembly will vary from application to application.

In many cases Duff-Norton can provide screw materials such as 316SS, longer screw lengths, or thread directions other than what has been cataloged.

Please contact our customer service department for assistance.



1/2 inch to 1-1/2 inch
bronze and plastic nuts
available in select T.P.I