

ACME SCREWS & NUTS

1-1/2 Inch (1.50 Inch) - Left Hand

Duff-Norton offers complete close mounted systems to complement these screw & nut assemblies as follows:

- Screw Journal Ends - Page 64
- End Blocks - Page 66
- Motor Flanges - Page 70
- Gearmotors - Page 76
- Controls - Page 96

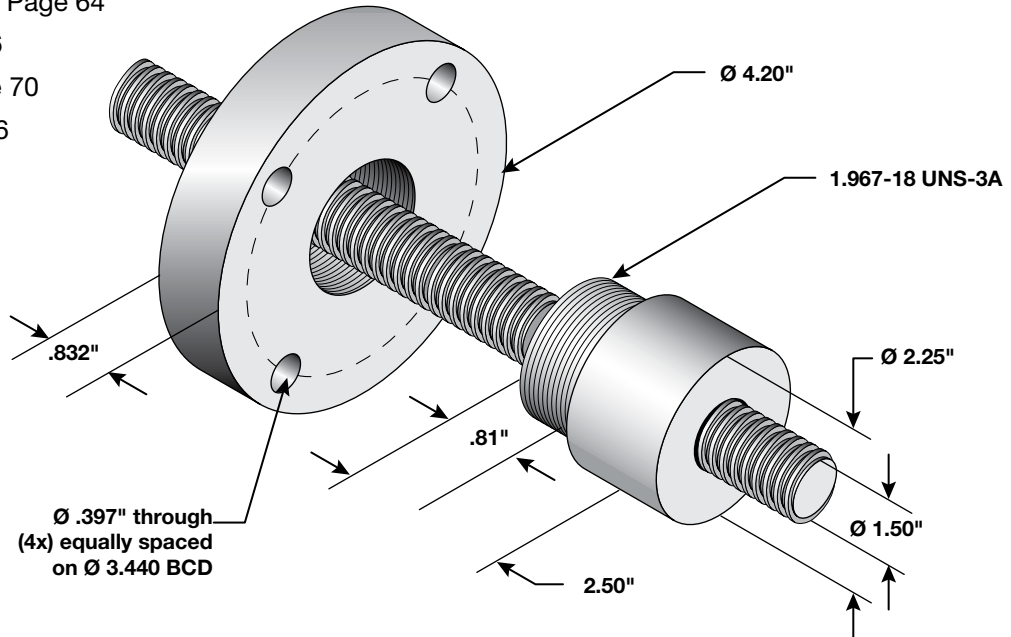

Acme Screw & Nut 1-1/2 Inch (1.50 Inch) Diameter - Left Hand

Acme Screw	Screw Dia.	Lead	Pitch	No. Starts	Root Dia.	Thread Form	Material	Maximum Backlash	Standard Lengths		
									36 Inch	72 Inch	144 Inch
150ASA010L	1.50	.100	.100	1	1.355	Centralizing LH	Steel	0.011	Yes	Yes	Yes
150ASA020L		.200	.200		1.280			0.008			
150ASA025L		.250	.250		1.215			0.007			
Acme Nut	*Static Load	*Dynamic Load	*Max. Speed	T.P.I.	Efficiency	Torque to Raise 1 Lb.	Material	Mounting Thread	Mounting Length	Nut Length	Nut Diameter
150ANB010L	56,206	18,037	172.50	10	14%	0.111	Bronze	1.967-18 UNF-3A	.81	2.50	2.25
150ANB020L	60,373	18,226	345.00	5	26%	0.123					
150ANB025L	59,393	18,992	431.25	4	31%	0.130					
150ANP025L	5,598	5,598			41%	0.097	Plastic				
Flange	Overall Dia.	Bolt Cir. Dia.	Bolt Hole Dia.	Mounting Holes	Flange Width	Treated	Material	Mounting Thread			
FL1967	4.20	3.440	.397	4	.832	Black Oxide	Steel	1.967-18 UNF-3B			

Note: Unless otherwise specified, all capacities are in Pounds, all dimensions are in Inches, and all speeds are in Inches per Minute.

*Load ratings are based on what the screw & nut assembly is capable of achieving. Actual load performance for a given screw and nut assembly will vary from application to application.

*Speed ratings are based on a directly coupled screw & motor turning at 1725 rpm. Actual speeds for a given screw and nut assembly will vary from application to application.

In many cases Duff-Norton can provide screw materials such as 316SS, longer screw lengths, or thread directions other than what has been cataloged.

Please contact our customer service department for assistance.



1/2 inch to 1-1/2 inch
bronze and plastic nuts
available in select T.P.I

ACME SCREWS & NUTS 1-1/2 Inch (1.50 Inch) - Right Hand

Duff-Norton offers complete close mounted systems to complement these screw & nut assemblies as follows:

- Screw Journal Ends - Page 64
- End Blocks - Page 66
- Motor Flanges - Page 70
- Gearmotors - Page 76
- Controls - Page 96

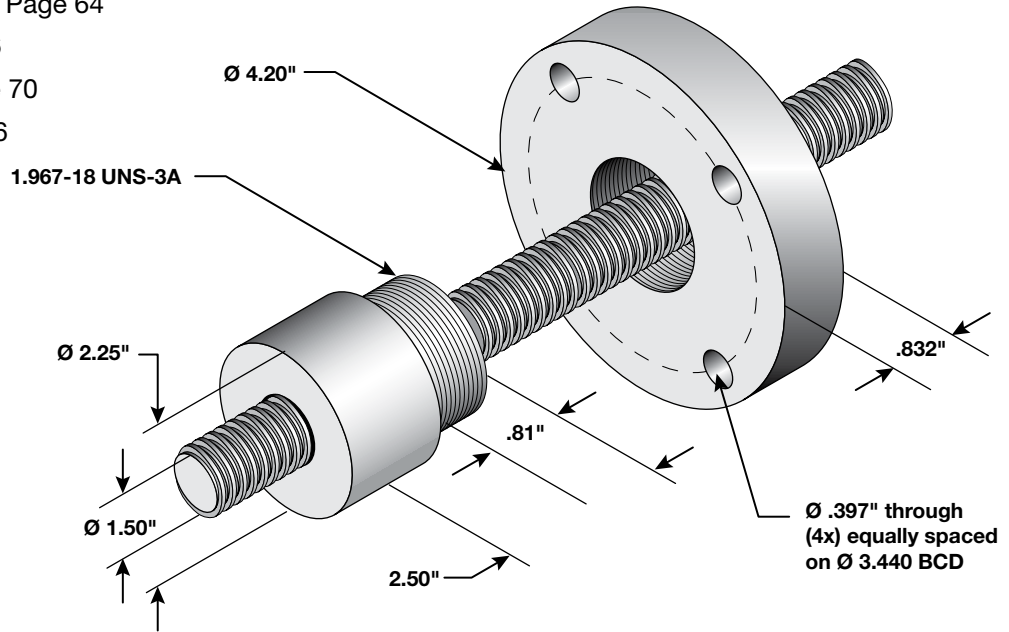

Acme Screw & Nut 1-1/2 Inch (1.50 Inch) Diameter - Right Hand

Acme Screw	Screw Dia.	Lead	Pitch	No. Starts	Root Dia.	Thread Form	Material	Maximum Backlash	Standard Lengths		
									36 Inch	72 Inch	144 Inch
150ASA010R	1.50	.100	.100	1	1.355	Centralizing RH	Steel	0.011	Yes	Yes	Yes
150ASA020R		.200	.200		1.280			0.008			
150ASA025R		.250	.250		1.215			0.007			
150ASA038R		.375	.375	1.053	0.016						
150ASA050R		.500	2.50	1.196	0.014						
150ASA100R		1.00		4	1.197			0.016			
Acme Nut	*Static Load	*Dynamic Load	*Max. Speed	T.P.I.	Efficiency	Torque to Raise 1 Lb.	Material	Mounting Thread	Mounting Length	Nut Length	Nut Diameter
150ANB010	56,206	18,037	172.50	10	14%	0.111	Bronze	1.967-18 UNF-3A	.81	2.50	2.25
150ANB020	60,373	18,226	345.00	5	26%	0.123					
150ANB025	59,393	18,992	431.25	4	31%	0.130					
150ANB038	53,749	20,180	646.88	2.67	39%	0.153					
150ANB050	52,926	17,197	862.50	2	46%	0.173					
150ANB100	5,066	5,066	1725.00	1	61%	0.261					
150ANP025	5,598	5,598	431.25	4	41%	0.097	Plastic				
150ANP038	5,066	5,066	646.88	2.67	50%	0.119					
150ANP050	4,988	4,988	862.50	2	57%	0.139					
150ANP100	4,752		1725.00	1	71%	0.225					
Flange	Overall Dia.	Bolt Cir. Dia.	Bolt Hole Dia.	Mounting Holes	Flange Width	Treated	Material	Mounting Thread			
FL1967	4.20	3.440	.397	4	.832	Black Oxide	Steel	1.967-18 UNF-3B			

Note: Unless otherwise specified, all capacities are in Pounds, all dimensions are in Inches, and all speeds are in Inches per Minute.

*Load ratings are based on what the screw & nut assembly is capable of achieving. Actual load performance for a given screw and nut assembly will vary from application to application.

*Speed ratings are based on a directly coupled screw & motor turning at 1725 rpm. Actual speeds for a given screw and nut assembly will vary from application to application.

In many cases Duff-Norton can provide screw materials such as 316SS, longer screw lengths, or thread directions other than what has been cataloged.

Please contact our customer service department for assistance.



1/2 inch to 1-1/2 inch bronze and plastic nuts available in select T.P.I