

SCREW JACK POWERED ACTUATORS

EXTERNAL POWER SOURCE AND GEAR REDUCER



All actuators require an external power source. Whether this power source be an electric motor or hand wheel Duff-Norton has the required component.

Customers who choose to power their actuators with an electric motor may do so by connecting the motor to the actuator via a C-face adapter, right angle gear reducer, or by remotely connecting the motor and actuator worm shaft with a coupling and connecting shaft.

Some customers opt to manually power their actuators. In those cases hand wheels are usually the preferred drive component.

Gear Reducer Driven

Duff-Norton provides customers with the most comprehensive and easily implemented motorized gear reducer assortment. For the first time customers can easily select the gear reducer model best suited for their application.

FEATURES

- Available on 2 Ton through 50 Ton, machine screw or ball screw actuators.
- Largest selection of gear reducer ratios available.
- Easy mounting simplifies installation, eliminates drive alignment problems.
- Field retrofit possible on most existing non-motorized models.
- Modular assembly allows many different arrangements. Most models can have parts repositioned in the field to solve clearance problems.
- Properly sized motor and gear reducer mounted directly to side of actuator. (See pgs. 141-144 for shafts & couplings, etc.)
- One motorized actuator can shaft drive one or more additional actuators.
- Reducer's aluminum and finned housings yield better cooling properties.
- Eliminates exposed shafts and couplings; no need to design and source shafts or couplings.
- 725 rpm, 230/460 volt, 3 phase TEFC motors standard. Other voltages and special motor features available.

SCREW JACK POWERED ACTUATORS

HOW TO SIZE A MOTORIZED GEAR REDUCER

Determine whether machine screw or ball screw actuators are to be used.

Determine if it is a single actuator application, or multiple actuators, shaft driven from a common motorized reducer.

For a single actuator:

1. Determine actuator load.
2. Refer to the tables on pages 110-114. Select an actuator model with adequate nominal load rating. Ratings larger than actual load may be required due to column strength, life requirements, etc.
3. Select a reducer ratio to provide a suitable lifting speed.
4. Go along that line of the table to find a load capacity equal to or greater than applied load. Note the motor horsepower from the top of the column.

NOTE

Ratings in the shaded area of the chart exceed the safe load rating of a single actuator and are shown for designing multiple actuator systems. In no case should an actuator be used at a higher load or input horsepower than shown in the actuator specification charts on pages 15, 39, 46, 55, 76 and 82.



For multiple actuators, shaft driven from a single reducer:

1. Determine total system load and distribution of load between actuators.
2. Refer to the tables on pages 110-113. Select an actuator model with nominal load rating adequate for the most heavily loaded actuator in the system.
3. Select a reducer ratio to provide a suitable lifting speed.
4. Go along that line of the table to find a load capacity equal to or greater than total system load. Note the motor horsepower from the top of the column.

SCREW JACK POWERED ACTUATORS

MACHINE SCREW ACTUATORS - PERFORMANCE SPECIFICATIONS

The gear reducers shown in this section are sized with adequate power ratings to allow a single actuator to be used at its full load or horsepower rating. For multiple actuator applications, the reducers shown may not provide adequate power to operate several actuators at full rating. Oversized reducers are available. Contact Duff-Norton Customer Service for multiple actuator applications if the total capacity is greater than shown.

Actuator Model	Actuator Ratio	Reducer Model	Reducer Ratio	Lifting Speed (in/min)	Lifting Capacity (lbs) - See Notes Below, Motor Horsepower (1725 RPM) / Frame Size											
					1/4 - 56C	1/3 - 56C	1/2 - 56C	3/4 - 56C	1 - 56C	1.5 - 140TC	2 - 140TC	3 - 180TC	5 - 180TC	7.5 - 180TC		
2 Ton MS	6:1	31	5	14.4	1320	1750	2650	3980	5300						Note: 180TC flange!	
			7.5	9.6	1900	2500	3800	5720	7620							
			10	7.2	2430	3200	4860									
			15	4.8	3290	4340	6500									
			20	3.6	4120	5440	8200									
			25	2.9	4900	6490										
			30	2.4	5100	6740										
3 Ton MS	6:1	40	5	14.4	1450	1930	2900	4350	5800	8700	11600					
			7.5	9.6	2080	2770	4160	6250	8330	12500						
			10	7.2	2725	3630	5450	8175	10900							
			15	4.8	3725	4960	7450	11200	14900							
			20	3.6	4700	6260	9400	14100								
			25	2.9	5650	7500	11300									
			30	2.4	6000	8000	12000									
5 Ton MS	6:1	50	5	21.9	925	1230	1950	2775	3700	5550	7400	11100			Note: Model 50 reducer requires 140 Frame motor for 3 HP application	
			7.5	14.5	1340	1780	2680	4010	5350	8020	10700	16090				
			10	10.9	1750	2330	3500	5250	7000	10500	14000					
			15	7.3	2425	3230	4850	7270	9700	14500	18000					
			20	5.5	3100	4140	6220	9320	12430	18000						
			25	4.4	3750	5000	7500	11260	15000							
			30	3.6	4040	5400	8090	12100	16200							
10 Ton MS	8:1	63	5	21.9	1120	1500	2240	3360	4480	6720	8960	13400	22400			
			7.5	14.5	1650	2200	3300	4940	6600	10000	13200	19800	33700			
			10	10.9	2150	2860	4290	6430	8580	12860	17150	25730				
			15	7.3	3025	4030	6050	9070	12090	18100	24180	36200				
			20	5.5	3880	5175	7760	11640	15520	23300	31000					
			25	4.4	4700	6260	9400	14100	18800	28200	37600					
			30	3.6	5150	6860	10300	15450	20600	30900	37700					
15 Ton MS	8:1	75	5	21.9	890	1200	1780	2680	3570	5350	7140	10700	17850	26750		
			7.5	14.5	1310	1750	2620	3930	5240	7860	10480	15700	26200	39300		
			10	10.9	1725	2300	3450	5170	6900	10340	13800	20700	34500			
			15	7.3	2440	3250	4875	7310	9750	14600	19500	29250	46400			
			20	5.5	3160	4210	6320	9480	12640	18960	25300	37900				
			25	4.4	3880	5180	7760	11650	15500	23300	31000	46400				
			30	3.6	4050	5390	8100	12100	16200	24200	32300					
20 Ton MS	8:1	75	5	21.9	830	1100	1660	2490	3320	4980	6640	9960	16600	24900		
			7.5	14.5	1220	1620	2440	3650	4870	7300	9740	14600	24300	36500		
			10	10.9	1600	2140	3200	4800	6410	9600	12800	19200	32000	43200		
			15	7.3	2270	3020	4530	6800	9060	13600	18100	27200	45000			
			20	5.5	2930	3900	5850	8780	11700	17550	23400	35100				
			25	4.4	3600	4800	7200	10800	14400	21600	28800	43200				
			30	3.6	3780	5030	7550	11300	15100	22650	30200	43200				
40	2.7	4950	6600	9900	14850	19800	29700	39600								

Using Reducer-Horsepower Tables

1. Listed actuator capacities consider reducer efficiencies and maximum power ratings.
2. Capacities are based on available reducer output torque and apply to both single actuator and shaft-connected, multiple actuator configurations. Capacity is the total load for all actuators driven by the reducer.
3. Shaded capacities exceed the single actuator load rating or horsepower rating. In no case should any actuator be loaded beyond its nominal load rating, or at input powers greater than shown in the actuator specification chart on page 15.
4. For multiple actuator configurations with total capacity greater than shown, contact Duff-Norton Application Engineering.

SCREW JACK POWERED ACTUATORS

MACHINE SCREW ACTUATORS - PERFORMANCE SPECIFICATIONS

Actuator Model	Actuator Ratio	Reducer Model	Reducer Ratio	Lifting Speed (in/min)	Lifting Capacity (lbs), Motor Horsepower (1725 RPM) / Frame Size									
					1 - 80L	1.5 - 90S	2 - 90L	3 - 100L	5 - 100L	7.5 -132S	10 -132M	15 - 160M	20 - 160L	
25 & 30 Ton MS	10.67:1	92672.1	4.36	24.7		5330	7090	10510	17470	26080	34950			
			5.64	19.1	4570	6890	9160	13600	22610	33740	45250			
			6.68	16.1	N.A.	8170	10870	16120	26800	39980	53600			
			7.44	14.5	6030	9100	12090	17950	29810	44480	59640			
			8.33	12.9	6750	10200	13550	20110	33420	49840	66800			
			9.39	11.5	7610	11480	15290	22650	37650	N.A.				
			10.16	10.6	8240	12430	16530	24520	40740	60780				
			11.39	9.5	9230	13940	18530	27470	45670					
			12.84	8.4	10400	15720	20870	30960	51480					
			14.40	7.5	11690	17635	23420	34750	57740					
			15.56	6.9	12630	19050	25310	37540	62400					
			17.46	6.2	14160	21370	28400	42140	70020					
			18.21	5.9	N.A.	22270	29610	43920						
			20.00	5.4	16210	24480	32540	N.A.						
			24.88	4.3	N.A.	30450	40470	60020						
			27.33	3.9	22160	33440	44460							
			30.67	3.5	24860	37520	49890							
			33.71	3.2	27340	41260	54840							
			37.82	2.9	30675	46280	61530							
			43.28	2.5	35110	52950								
48.56	2.2	39390	59400											
35 Ton MS	10.67:1	92772.1	4.17	25.9						19350	25970			
			5.12	21.1		4860	6470	9590	15940	23780	31900			
			6.39	16.9		N.A.	N.A.	N.A.	N.A.	N.A.	29700	39800		
			7.18	15.0		6820	9080	13450	22360	33370	44730			
			8.85	12.2	5580	8410	11180	16590	27560	41100	55125			
			9.81	11.0	N.A.	9320	12400	18390	30570	45600	61140			
			11.28	9.6	7100	10720	14260	21150	35150	52430	70300			
			12.50	8.6	7870	11880	15800	23430	38930	58080	77890			
			13.79	7.8	8700	13100	17430	25840	42960	N.A.	N.A.			
			15.42	7.0	9710	14660	19490	28910	48030	71660	96075			
			17.08	6.3	10760	16240	21600	32025	53210	79400	106450			
			18.84	5.7	11880	17920	23800	35330	58710	89070				
			19.17	5.6	12075	18210	24230	35920	59710					
			21.14	5.1	13310	20100	26720	39630	65870					
			22.59	4.8	14220	21470	28560	42350	70380					
			24.64	4.4	15520	23430	31150	N.A.	N.A.					
			25.34	4.3	15980	24100	32040	47510	78960					
			27.65	3.9	17430	26280	34950	N.A.						
			31.85	3.4	N.A.	N.A.	N.A.	59710						
			35.04	3.1	N.A.	33320	44290	65700						
39.32	2.7	N.A.	37380	49700	73700									
43.44	2.5	27380	41300	54910										
46.92	2.3	29575	44600	59300										
52.64	2.0	33180	50050	66550										
59.68	1.8	37600	56730											
66.96	1.6	42190	63660											
50 Ton MS	10.67:1	9042	8.83	12.2							42800	63400	84500	
			9.39	11.5							45400	67400	89900	
			10.21	10.6								49400	73300	97700
			11.40	9.5								55300	82000	109000
			13.40	8.0							48800	65100	96300	128000
			15.66	6.9							56800	75800	112000	150000
			18.20	5.9							66300	88500	130000	173000
			20.32	5.3							74200	99000	145000	193000
			23.89	4.5							86400	115000	170000	227000
			27.91	3.9							101000	135000	200000	
			31.70	3.4							114000	153000		
			34.39	3.1						84000	126000	168000		
			40.54	2.7						97700	146000	195000		
			47.67	2.3						116000	175000			
55.69	1.9					81300	135000	203000						

The 25 and 30 ton actuators use the same gear reducer. Cells shaded in light blue show capacities which are acceptable for the 30 ton actuator only. Cells shaded in dark blue show capacities not acceptable for either actuator.

Charts show available ratios and motors for close-coupled, IEC frame motors. Gear reducers with flange for NEMA C-face motor also available. Fitting of C-face motor will increase length of reducer-motor combination.

SCREW JACK POWERED ACTUATORS

BALL SCREW ACTUATORS - PERFORMANCE SPECIFICATIONS

Actuator Model	Actuator Ratio	Reducer Model	Reducer Ratio	Lifting Speed (in/min)	Lifting Capacity (lbs), Motor Horsepower (1725 RPM) / Frame Size								
					.50 - 71L	.75 - 80S	1 - 80L	1.5 - 90S	2 - 90L	3 - 100L	5 - 100L	7.5 - 132S	10 - 132M
25 Ton BS	10.67:1	92372.1	3.72	28.7				12240	16300	24120	40120		
			4.31	24.8			9390	14180	18850	27940	46480		
			5.13	20.8			11210	16900	22420	33270	55330		
			5.83	18.3		9750	12720	19210	25510	37880	62970		
			6.67	16.0		11150	14540	21940	29210	43270	71940		
			7.01	15.2		11760	15270	23090	30670	45510	75630		
			8.19	13.0		13760	17880	26970	35880	53210	88424		
			9.11	11.7		15270	19880	30000	39880	59150	98300		
			10.22	10.4		17150	22300	33630	44730	66360	110300		
			10.33	10.3		17333	22550	34000	45210	72720			
			11.20	9.5		18790	24420	36850	49030	81570			
			12.56	8.5		21030	27450	41390	55030				
			14.12	7.6		23630	30850	46480	61800				
			15.84	6.7		26540	34600	52180	69390				
			18.33	5.8		30730	40000	60360	80240				
			20.04	5.3		33575	43750	66000	87750				
			22.49	4.7		37700	49090	74060	98420				
			25.06	4.3		42000	54660	82480	109700				
			28.11	3.8		47090	61330	92540					
			32.80	3.3	36424	54970	71575	10800					
36.80	2.9	40850	61636	80300									
41.46	2.6	46060	69450	90480									
46.64	2.3	51760	78120										
49.46	2.2	54910											
55.49	1.9	61630											
50 Ton BS (Reverse base only)	10.67:1	92672.1	4.36	37.1								52640	70540
			5.64	28.7							45640	68090	91300
			6.68	24.2							54090	80680	108180
			7.44	21.7							60180	89780	120360
			8.33	19.4							67450	100590	134860
			9.39	17.2						45730	76000	N.A.	
			10.16	15.9						49500	82230	122680	
			11.39	14.2						55450	92180		
			12.84	12.6						62500	103900		
			14.40	11.2					47270	70130	116540		
			15.56	10.4					51090	75770	125950		
			17.46	9.3					57320	85040	141300		
			18.21	8.9					59770	88640			
			20.00	8.1				49400	65680	N.A.			
			24.88	6.5				61450	81680	121130			
			27.33	5.9				67500	89730				
			30.67	5.3			50180	75730	100680				
			33.71	4.8			55180	83270	110680				
37.82	4.3	47500	61900	93410	124180								
43.28	3.7	54300	70860	106860									
48.56	3.3	61000	79500	119900									

Using Reducer-Horsepower Tables

1. Listed actuator capacities consider reducer efficiencies and maximum power ratings.
2. Capacities are based on available reducer output torque and apply to both single actuator and shaft-connected, multiple actuator configurations. Capacity is the total load for all actuators driven by the reducer.
3. Capacities in italics exceed the single actuator load rating or horsepower rating. In no case should any actuator be loaded beyond its nominal load rating, or at input powers greater than shown in the actuator specification chart on page 55.
4. For multiple actuator configurations with total capacity greater than shown, contact Duff-Norton Application Engineering.

SCREW JACK POWERED ACTUATORS

CONTINUOUS DUTY ACTUATORS - PERFORMANCE SPECIFICATIONS

Actuator Model	Actuator Ratio	Reducer Model	Reducer Ratio	Lifting Speed (in/min)	Lifting Capacity (lbs) - See Previous Notes, Motor Horsepower (1725 rpm) / Frame Size								
					1/4 - 56C	1/3 - 56C	1/2 - 56C	3/4 - 56C	1 - 56C	1.5 - 140TC	2 - 140TC	3 - 180TC	5 - 180TC
7511 (3,500 lbs Max)	6:1	31	5	14.4	2200	3100	4700	7000	9400				
			7.5	9.6	3380	4500	6750	10100					
			10	7.2	4300	5700	8620						
			15	4.8	5840	7700							
			20	3.6	7300	9650							
7515 (12,000 lbs Max)	8:1	63	5	20.4	2880	3860	5770	8700	11500	17300	23200	34750	
			7.5	13.6	4260	5670	8500	12800	17000	25500	34125		
			10	10.2	5560	7350	11100	16590	22100	33280			
			15	6.8	7820	10400	15640	23400	31300				
			20	5.1	10000	13350	20000	30000					
75151 High Lead (5,500 lbs)	8:1	63	5	43.0	1240	1650	2480	3720	4960	7450	9940	14900	
			7.5	28.7	1820	2400	3650	5480	7300	10900	14600		
			10	21.5	2370	3140	4750	7140	9500	14250	19000		
7522 (27,000 lbs Max)	10.67:1	75	5	27.2	3200	4300	6460	9700	12930	19400	25860	38800	64650
			7.5	18.2	4750	6320	9500	14250	19000	28500	38000	57000	
			10	13.6	6250	8320	12500	18750	25000	37500	50000	75000	
			15	9.1	8800	11700	17590	26380	35180	52750	70360		
75221 High Lead (13,500 lbs)	10.67:1	75	5	57.4	1600	2150	3230	4850	6460	9700	12900	19400	
			7.5	38.4	2375	3160	4750	7120	9500	14250	19000	28500	
			10	28.7	3125	4160	6250	9370	12500	18750	25000	37500	

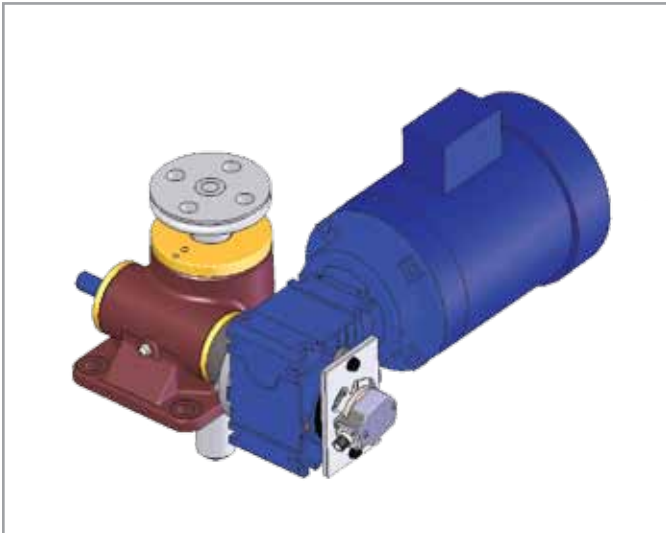

Does your application require mounting the limit switch or encoder on the reducer to allow another component to be mounted to the actuator's other side? No problem! Call our Customer Service team for assistance.

SCREW JACK POWERED ACTUATORS

MOTORIZED ACTUATOR - DIMENSIONS

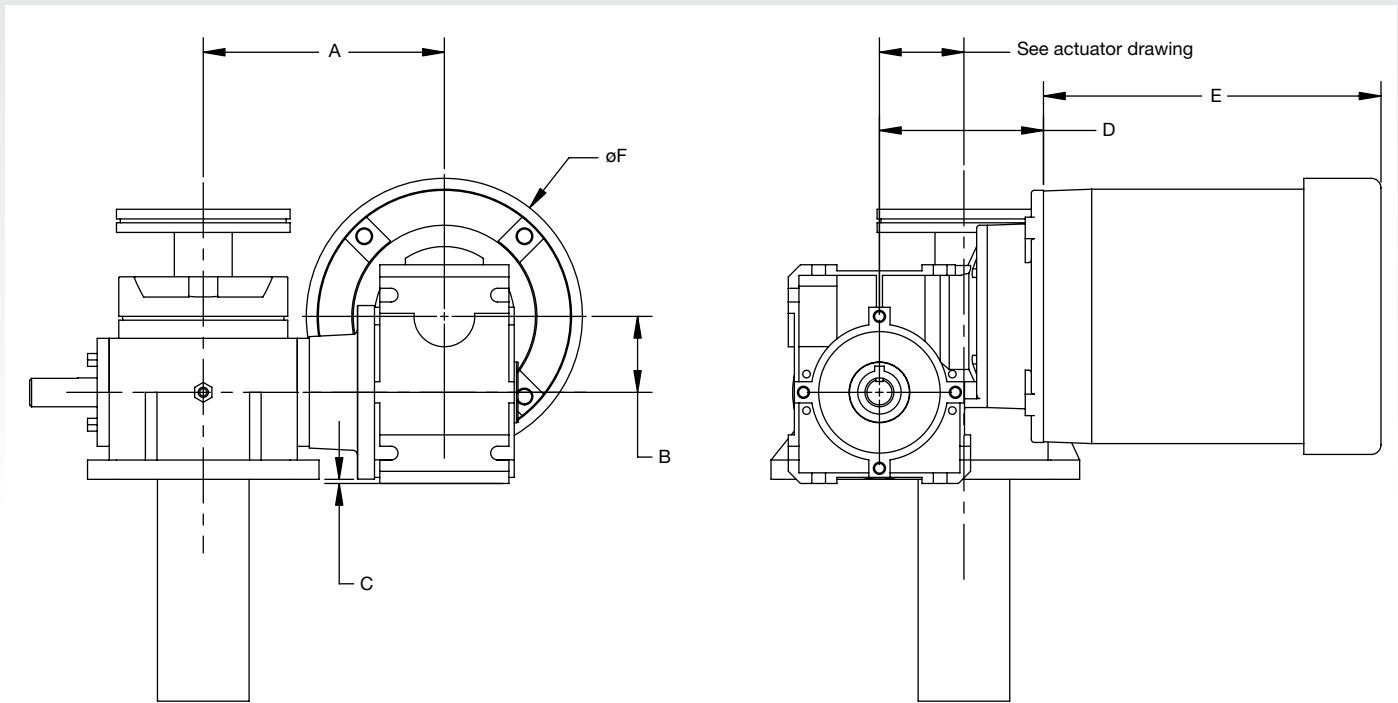

Actuator Capacity (tons)	Reducer Model	Motor Frame	A (in)	B (in)	C (in)	D (in)
2	31	56C	6.75	1.22	.17 Above	1.14
3	40	56C	6.75	1.57	.22 Below	4.17
		140TC	6.75	1.57	.22 Below	4.64
5	50	56C	6.25	1.97	.11 Below	4.26
		140TC	6.25	1.97	.11 Below	4.73
10	63	56C	7.59	2.48	.59 Below	4.85
		140TC	7.59	2.48	.59 Below	5.32
		180TC	7.59	2.48	.59 Below	6.45
15	75	56-140TC	7.40	2.95	.40 Below	6.09
		180TC	7.40	2.95	.40 Below	6.96
20	75	56-140TC	7.68	2.95	.14 Below	6.09
		180TC	7.68	2.95	.14 Below	6.96
25 & 30	92672	80	7.40	2.68	.40 Above	7.08
		90-100	7.40	2.68	.40 Above	7.63
		132	7.40	2.68	.40 Above	7.95
35	92772	80	11.49	2.87	.92 Below	7.95
		90-100	11.49	2.87	.92 Below	8.50
		132	11.49	2.87	.92 Below	9.09
50	9042	100-160	11.64	1.42 Below	3.80 Below	9.72

Motor HP	Frame	Motor Without Brake		Motor With Brake	
		E (in)	F (in)	E (in)	F (in)
0.25	56C	7.50	7.16	11.50	7.16
0.33	56C	7.50	7.16	11.50	7.16
0.50	56C	8.00	7.16	13.00	7.16
0.75	56C	8.75	7.16	13.00	7.16
1	56C	9.25	7.16	13.50	7.16
1.5	140TC	9.75	7.16	15.00	7.16
2	140TC	10.75	7.16	16.00	7.16
3	180TC	11.37	9.22	16.12	9.22
5	180TC	11.87	9.22	16.62	9.22
7.5	210TC	16.50	10.81	22.25	10.81
10	210TC	22.87	10.81	25.00	10.81
0.25	63L	7.56	5.12	9.76	5.12
0.33	71S	8.43	5.71	10.71	5.71
0.50	71L	8.43	5.71	10.71	5.71
0.75	80S	9.29	6.50	11.81	6.50
1	80L	9.29	6.50	11.81	6.50
1.5	90S	10.87	7.20	13.82	7.20
2	90L	10.87	7.20	13.82	7.20
3	100L	12.05	7.91	15.63	7.91
5	100L	12.05	7.91	15.63	7.91
7.5	132S	12.83	8.89	16.49	8.98
10	132M	16.41	10.47	20.59	10.47
15	160M	18.83	12.60	25.40	12.60
20	160L	18.83	12.60	25.40	13.60

NOTE

- Motors in shaded portion of table are close-coupled, IEC frame, standard on 25 to 50 ton actuators with reducers.

NEMA C-face motors can be fitted to 25-50 ton units, with some increase in length. IEC frame motors can also be fitted to all other reducers, to reduce motor envelope size.
- Dimensions for NEMA C-face motors are typical for 1725 rpm, 3-phase, TEFC motors. Dimensions may vary somewhat depending on manufacturer.

SCREW JACK POWERED ACTUATORS REDUCER POSITIONS

Reducer Positions 2-20 Tons

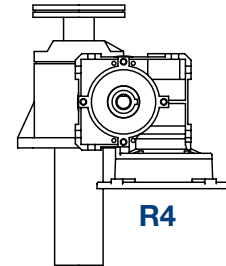
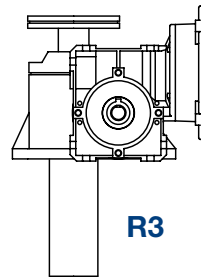
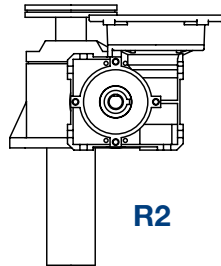
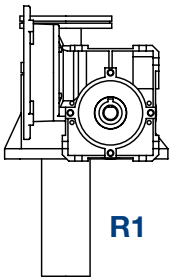
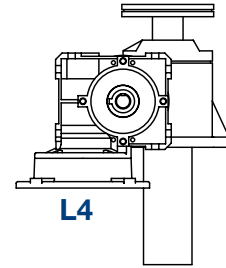
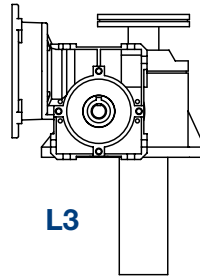
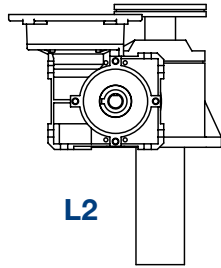
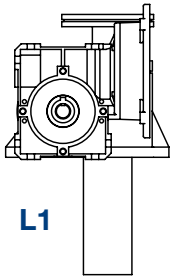

Reducer Positions 25-50 Tons

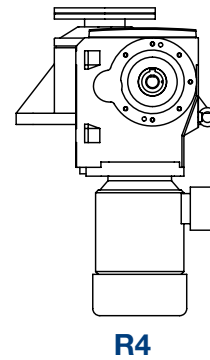
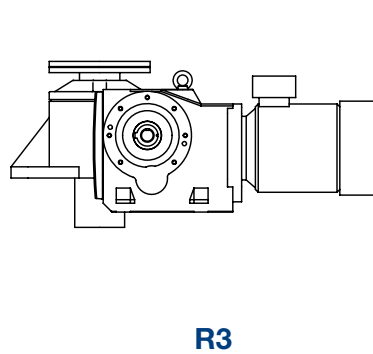
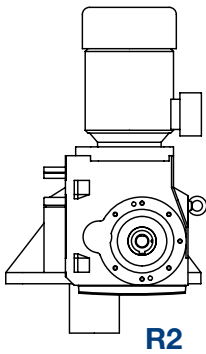
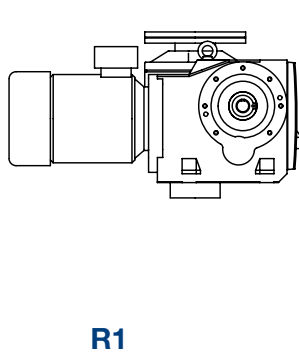
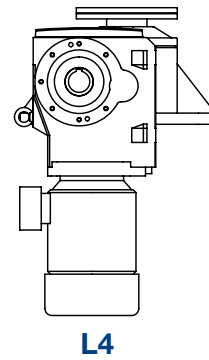
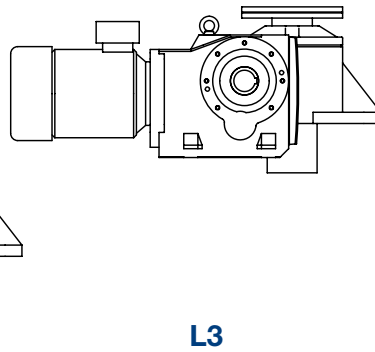
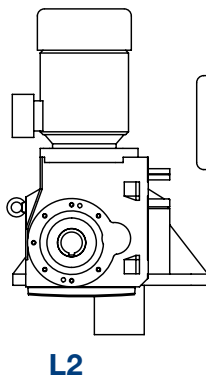
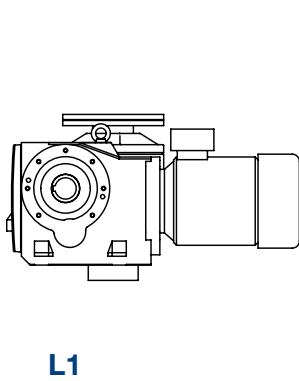

SCREW JACK POWERED ACTUATORS ACTUATOR MOTORS

Duff-Norton can competitively supply motors for any application from suppliers such as Baldor, Nord, US Electric, Leeson, and more.

Motors can be directly mounted to most Duff-Norton actuators using C-face adapters, directly mounted via speed reducers, or remotely mounted with shafting and couplings. IEC, servo, hydraulic, and air motors can also be supplied upon request.



FEATURES

Standard Motors Include:

- Brake and non-brake models
- Single and three phase models
- Explosion proof, washdown duty
- Wide variety of voltages and RPM's
- 50/60Hz models
- ¼ to 10 Horsepower ratings
- Common NEMA frame size

SCREW JACK POWERED ACTUATORS C-FACE MOTOR DRIVEN

Performance Specifications															
Actuator Capacity	Worm Gear Ratio	Lifting Speed (in/min)		Lifting Capacity (lbs)											
				Motor Horsepower											
		Motor RPM		1/2	1/2	3/4	3/4	1	1	1-1/2	1-1/2	2	2	3	5
		1725	1140	1725	1140	1725	1140	1725	1140	1725	1140	1725	1140	1725	1140
2 Ton MS	6:1	71.9	47.5	450	770	760	1240	1070	1710	1700	2660	2330	3600	—	—
	12:1	35.9	23.8	740	1260	1250	2040	—	—	—	—	—	—	—	—
	24:1	18.0	11.9	1150	1970	—	—	—	—	—	—	—	—	—	—
	25:1	17.3	11.4	1200	2060	2040	3320	—	—	—	—	—	—	—	—
3 Ton MS	6:1	71.9	47.5	480	830	820	1340	1160	1840	1830	2860	2510	3880	—	—
	12:1	35.9	23.8	780	1320	1320	2140	1860	2950	—	—	—	—	—	—
	24:1	18.0	11.9	1110	1890	1880	3060	—	—	—	—	—	—	—	—
	25:1	17.3	11.4	1160	1980	1970	3200	2770	4410	—	—	—	—	—	—
5 Ton MS	6:1	107.8	71.3	—	390	380	690	590	1000	1000	1620	1400	2240	2220	—
	12:1	53.9	35.6	300	640	640	1160	980	1670	1660	2690	2340	3720	—	—
	24:1	27.0	17.8	450	980	970	1750	—	—	—	—	—	—	—	—
	25:1	17.3	11.4	480	1040	1030	1860	—	—	—	—	—	—	—	—
10 Ton MS	8:1	107.8	71.3	—	190	190	560	430	940	930	1680	1420	2420	2410	4360
	24:1	35.9	23.8	—	370	360	1090	840	1800	1790	3230	—	—	—	—
	25:1	17.3	11.4	—	400	400	1180	910	1960	1940	3510	—	—	—	—
	8:1	107.8	71.3	—	150	140	440	340	730	720	1300	1100	1880	1870	3400
15 Ton MS	24:1	35.9	23.8	—	260	260	770	600	1280	1270	2300	—	—	—	—
	25:1	17.3	11.4	—	340	330	1000	770	1660	1640	2970	—	—	—	—
	8:1	107.8	71.3	—	—	—	240	130	540	530	1150	940	1760	1750	3370
	24:1	35.9	23.8	—	—	—	420	230	960	950	2040	—	—	—	—
20 Ton MS	25:1	17.3	11.4	—	—	—	480	260	1080	1070	2300	—	—	—	—
	10-2/3:1	107.7	71.2	—	—	—	—	—	320	320	950	730	1570	1560	3210
	32:1	17.3	11.4	—	—	—	—	—	520	510	1520	1170	2520	—	—
	32:1	13.5	8.9	—	—	—	—	—	490	480	1420	1090	2350	—	—
35 Ton MS	10-2/3:1	107.7	71.2	—	—	—	—	—	—	—	550	390	1030	1020	2300
	32:1	35.9	23.7	—	—	—	—	—	—	—	930	650	1740	—	—
	32:1	17.3	11.4	—	—	—	—	—	—	—	1100	760	2050	—	—
	6:1	71.9	47.5	1270	2050	2040	3210	2800	4360	4340	6680	5870	9880	—	—
2 Ton BS	24:1	18.0	11.9	2720	4390	—	—	—	—	—	—	—	—	—	—
	12:1	35.9	23.8	2220	3580	3550	—	—	—	—	—	—	—	—	—
	6:1	287.5	190.0	180	400	400	720	610	1040	1030	1680	1450	2320	—	—
	24:1	71.9	47.5	450	980	—	—	—	—	—	—	—	—	—	—
2 Ton BS High Lead	12:1	143.8	95.0	320	680	680	1220	—	—	—	—	—	—	—	—
	6:1	118.7	78.5	740	1260	1250	2040	1770	2810	2800	4370	3830	5920	—	—
	24:1	71.9	47.5	1730	2950	—	—	—	—	—	—	—	—	—	—
	12:1	59.4	39.2	1230	2110	—	—	—	—	—	—	—	—	—	—
5 Ton BS	6:1	136.0	89.9	380	810	810	1460	1230	2110	2090	3400	2950	4690	4660	—
	24:1	34.0	22.5	1000	2140	2120	3840	—	—	—	—	—	—	—	—
	12:1	68.0	44.9	590	1270	1260	2270	1920	3280	3260	5290	4590	7300	—	—
	6:1	287.5	190.0	—	140	140	430	330	710	700	1280	1080	1840	1830	—
5 Ton BS High Lead	24:1	71.9	47.5	—	380	370	1110	—	—	—	—	—	—	—	—
	12:1	143.8	95.0	—	250	250	740	570	1220	1210	2190	1850	3160	—	—
	8:1	102.0	67.4	170	720	710	1530	1250	2340	2350	4050	3450	5700	5600	10000
	24:1	34.0	22.5	370	1520	1500	3210	2620	4910	4950	8450	—	—	—	—
10 Ton BS	8:1	215.6	142.5	—	180	170	530	410	880	870	1570	1330	2270	2250	4100
	24:1	71.9	47.5	—	370	360	1090	840	1800	1790	3230	—	—	—	—
	8:1	107.8	71.3	—	—	—	40	—	860	850	2600	2000	4250	4200	8600
	24:1	35.9	23.8	—	—	—	100	—	2010	2050	6000	—	—	—	—
20 Ton BS	8:1	215.6	142.5	—	—	—	—	—	130	120	950	660	1770	1750	3920
	24:1	71.9	47.5	—	—	—	—	—	300	1000	2900	—	—	—	—
	10-2/3:1	106.7	70.5	—	—	—	40	—	800	790	2340	1800	3970	3840	7910
	32:1	35.6	23.5	—	—	—	80	—	1640	1610	4760	3680	7890	—	—
7511	6:1	118.7	78.5	650	1100	1100	1780	1550	2460	2450	3820	3350	5180	—	—
7515	8:1	102.0	67.4	500	1080	1070	1940	1640	2790	2780	4510	3910	6230	6190	10740
75151 HL	8:1	215.6	142.5	—	90	80	260	200	430	430	780	660	1130	1120	2040
7522	10-2/3:1	80.9	53.4	—	—	—	50	—	1010	990	2940	2270	4870	4830	9950
75221 HL	10-2/3:1	161.7	106.9	—	—	—	—	—	70	70	540	380	1020	1010	2260

FEATURES

- Available for 2-35 Ton machine, 2-25 Ton ball screw, and all 7500 Series continuous duty cycle actuators.
- Designed with Standard NEMA C-face dimensions.
- Allows direct coupling of motor shaft with either the left or right side actuator input shaft.
- Comes with coupling, keys, and mounting hardware.

Motor Frame Sizes		
Motor HP	Motor RPM	
	1725	1140
1/2	56C	56C
3/4	56C, 143C	56C, 143C
1	56C, 143C	56C, 143C
1-1/2	56C, 143C	182C
2	56C, 143C	184C
3	—	182C
5	—	182C

SCREW JACK POWERED ACTUATORS C-FACE MOTOR DRIVEN

Please provide the following information when ordering:

- Actuator model
- Translating or rotating screw
- Upright or inverted configuration
- Type of screw end (translating screw actuators)
- Worm gear ratio
- Travel
- With or without boot
- With or without anti-backlash feature (machine screw actuators)
- Motor horsepower
- Motor frame size
- Left or right motor adaptor position
- Other special requirements

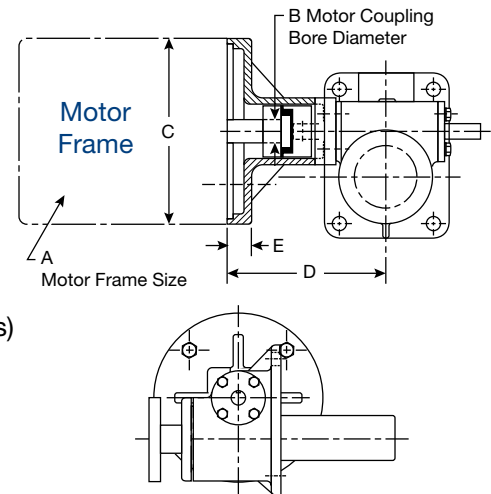

⚠ CAUTION

When direct coupling a motor to an actuator, it is necessary to match motor horsepower to actuator load. Lifting speeds and maximum actuator load capacities for actuators with various motor horsepower are shown in the table on the previous page. It is important that motors do not exceed the maximum horsepower shown.

⚠ CAUTION

All ball screw and high duty cycle actuators are self lowering and require motors with brakes. Standard ratio machine screw actuators are not always self locking and require motors with brakes. Optional ratio machine screw actuators are usually self-locking and do not require brakes. However, if self-locking is absolutely necessary, a motor brake or other restraining device should be considered.

Dimensions					
Capacity	A	B (+.001/-0.000)	C	D	E
2 Ton MS & BS, 3 Ton BS	56C	.625	6.75	6.16	.50
	143TC, 145TC	.875	6.75	6.16	.50
3 Ton MS	56C	.625	6.75	6.17	.50
	143TC, 145TC	.875	6.75	6.17	.50
5 Ton MS & BS	56C	.625	6.75	7.12	.62
	143TC, 145TC	.875	6.75	7.12	.62
	182TC, 184TC	1.125	9.00	7.95	1.45
10 Ton MS & BS	56C	.625	6.75	8.13	.65
	143TC, 145TC	.875	6.75	8.13	.65
	182TC, 184TC	1.125	9.00	8.89	1.47
15 Ton MS	56C	.625	6.75	8.13	.70
	143TC, 145TC	.875	6.75	8.13	.70
	182TC, 184TC	1.125	9.00	8.97	1.54
20 Ton MS & BS	56C	.625	6.75	8.13	.65
	143TC, 145TC	.875	6.75	8.13	.65
	182TC, 184TC	1.125	9.00	8.97	1.49
25 & 30 Ton MS & BS	56C	.625	6.75	8.88	.74
	143TC, 145TC	.625	6.75	8.88	.74
	182TC, 184TC	1.125	9.00	9.63	1.49
35 Ton MS	56C	.625	6.75	8.88	.65
	143TC, 145TC	.875	6.75	8.88	.65
	182TC, 184TC	1.125	9.00	9.63	1.49
7511	56C	.625	6.75	6.98	.50
	143TC, 145TC	.875	6.75	6.98	.50
7515	56C	.625	6.75	8.06	.65
	143TC, 145TC	.875	6.75	8.06	.65
	182TC, 184TC	1.125	9.00	8.90	1.47
7522	56C	.625	6.75	9.62	.65
	143TC, 145TC	.875	6.75	9.62	.65
	182TC, 184TC	1.125	9.00	10.46	1.49

SCREW JACK POWERED ACTUATORS

IEC MOTOR DRIVEN - B-FACE MOTOR ADAPTOR

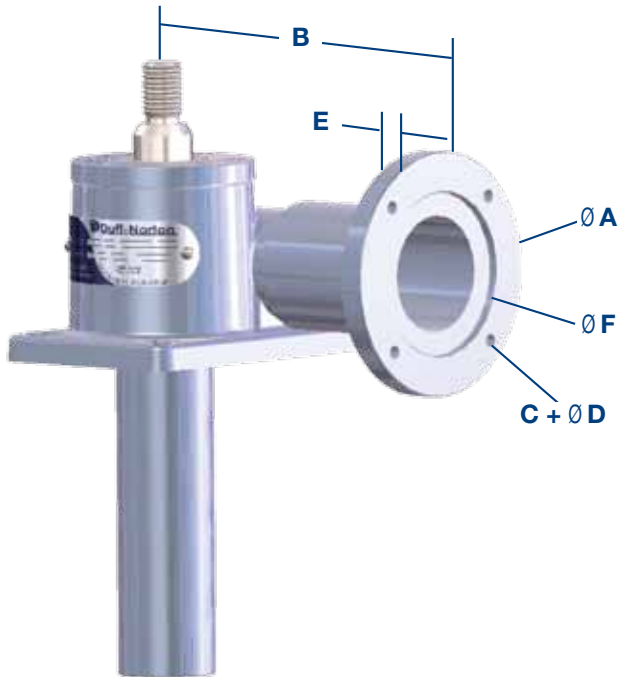

FEATURES

- Available for 25-200 kN G series screw jacks.
- Designed with Standard IEC B-face dimensions.
- Allows direct coupling of motor shaft with either the left or right side actuator input shaft.
- Comes with coupling, keys, and mounting hardware.
- NEMA motor adapters for our G series actuators are also available.

Dimensions							
Capacity	IEC/Servo Flanges	A Flange O.D.	B Flange Length**	C Mounting Holes B.C.	D Mounting Holes Diameter	E Mounting Hole Depth	F Counter Bore Diameter
25kN - G9002	G9002 - 63B14	90	126	75	6	12.7	60
	G9002 - 71B14	105	133	85	7	12.7	70
	G9002 - 80B14	120	143	100	7	12.7	80
	G9002 - 90B14	140	153	115	9	12.7	95
50kN - G9005	G9005 - 71B5	160	178	130	M8 Tap	12.4	110
	G9005 - 80B5	200	178	165	M10 Tap	12.4	130
	G9005 - 90B5	100	178	165	M10 Tap	12.4	130
	G9005 - 100B14	160	181	130	9	15.7	110
	G9005 - 112B14	160	181	130	9	15.7	110
100kN - G9010	G9010 - 80B5	200	203	165	M10 Tap	12.2	130
	G9010 - 90B5	200	203	165	M10 Tap	12.2	130
	G9010 - 100B14*	190	213	130	9	10.0	110
	G9010 - 112B14*	190	213	130	9	10.0	110
150kN - G9015	G9015 - 80B5	200	203	165	M10 Tap	12.2	130
	G9015 - 90B5	200	203	165	M10 Tap	12.2	130
	G9015 - 100B14*	190	213	130	9	10.0	110
	G9015 - 112B14*	190	213	130	9	10.0	110
200kN - G9020	G9020 - 80B5	200	213	165	M10 Tap	20.1	130
	G9020 - 90B5	200	213	165	M10 Tap	20.1	130
	G9020 - 100B14*	190	223	130	9	10.0	110
	G9020 - 112B14*	190	223	130	9	10.0	110
300kN - G9030	G9030 - 80B5	200	257	165	M10 Tap	20.1	130
	G9030 - 90B5	200	257	165	M10 Tap	20.1	130
	G9030 - 100B14*	190	267	130	9	10.0	110
	G9030 - 112B14*	190	267	130	9	10.0	110

Note: All dimensions are shown in millimeters. All couplings are purchased separately from the motor flange kit.

Use an adapter plate mounted to the G9010-80B5, G9015-80B5, G9020-80B5 and G9030-80B5 Flanges respectively.

Adapter plates should be mounted to the motor, and then to the motor flange

Mounts to the jacks' casting, and replaces the worm cover

SCREW JACK POWERED ACTUATORS

IEC MOTOR DRIVEN - B-FACE MOTOR ADAPTOR

Please provide the following information when ordering:

- Actuator model
- Worm gear ratio
- With or without anti-backlash feature (machine screw actuators)
- Motor horsepower
- Motor frame size
- Left or right motor adaptor position
- Other special requirements

Performance Specifications for 50 Hz Motor												
Actuator Capacity	Worm Gear Ratio	Speed (mm/min)	Lifting Capacity (Newtons)									
			Motor kW									
		RPM	0.12	0.18	0.25	0.37	0.55	0.75	1.10	1.50	2.20	3.70
			Motor RPM at 50 Hz									
		1450	1450	1450	1450	1450	1450	1450	1450	1450	1450	1450
25 kN	6:1	1450	290	800	1380	2400	3910	5600	5490	7860	—	—
	12:1	725	650	1780	3090	5340	8710	—	—	—	—	—
	24:1	362.5	470	1270	2210	3830	—	—	—	—	—	—
50 kN	6:1	2175	—	—	460	1170	2230	3420	5490	7860	1200	—
	12:1	1087.5	—	—	990	2510	4800	7340	11780	16860	—	—
	24:1	543.75	—	—	720	1830	3500	—	—	—	—	—
100 kN	8:1	2175	—	—	—	—	1180	2330	4340	6630	10640	19240
	24:1	725	—	—	—	—	2230	4390	8170	—	—	—
150 kN	8:1	2175	—	—	—	—	1180	2140	3990	6110	9810	17730
	24:1	725	—	—	—	—	2230	4050	7540	—	—	—
200 kN	8:1	2175	—	—	—	—	170	1130	2830	4770	8160	15420
	24:1	725	—	—	—	—	320	2140	5340	—	—	—
300 kN	10-2/3:1	2175	—	—	—	—	—	—	950	2530	5300	11220
	32:1	725	—	—	—	—	—	—	1590	4230	—	—

Ratings with N.A. in their cells have either exceeded the B-face flange frame size, or the single screw jack kilowatt rating. In no case should any screw jack be loaded or have a power supply beyond its' rating or damage will likely result.

Performance Specifications for 60 Hz Motor												
Actuator Capacity	Worm Gear Ratio	Speed (mm/min)	Lifting Capacity (Newtons)									
			Motor kW									
		RPM	0.12	0.18	0.25	0.37	0.55	0.75	1.10	1.50	2.20	3.70
			Motor RPM at 60 Hz									
		1700	1700	1700	1700	1700	1700	1700	1700	1700	1700	1700
25 kN	6:1	1700	140	570	1080	1940	3230	4670	7180	—	—	—
	12:1	850	320	1280	2400	4320	7200	—	—	—	—	—
	24:1	425	230	920	1720	3100	—	—	—	—	—	—
50 kN	6:1	2550	—	—	240	850	1760	2760	4530	6550	10080	17650
	12:1	1275	—	—	520	1820	3770	5940	9730	14060	—	—
	24:1	637.5	—	—	380	1330	2750	—	—	—	—	—
100 kN	8:1	2550	—	—	—	—	720	1700	3410	5360	8790	16120
	24:1	850	—	—	—	—	1360	3200	6430	—	—	—
150 kN	8:1	2550	—	—	—	—	660	1560	3140	4940	8100	14860
	24:1	850	—	—	—	—	1250	2950	5920	—	—	—
200 kN	8:1	2550	—	—	—	—	—	600	2050	3700	6590	12780
	24:1	850	—	—	—	—	—	1140	3860	—	—	—
300 kN	10-2/3:1	2550	—	—	—	—	—	—	310	1660	4020	9070
	32:1	850	—	—	—	—	—	—	520	2770	—	—

Ratings with N.A. in their cells have either exceeded the B-face flange frame size, or the single screw jack kilowatt rating. In no case should any screw jack be loaded or have a power supply beyond its' rating or damage will likely result.

⚠ CAUTION

When direct coupling a motor to an actuator, it is necessary to match motor horsepower to actuator load. Lifting speeds and maximum actuator load capacities for actuators with various motor horsepower are shown in the tables above. It is important that motors do not exceed the maximum horsepowers shown.

⚠ CAUTION

Standard ratio machine screw actuators are not always self locking and require motors with brakes. Optional ratio machine screw actuators are usually self-locking and do not require brakes. However, if self-locking is absolutely necessary, a motor brake or other restraining device should be considered.

SCREW JACK POWERED ACTUATORS ACTUATOR HAND WHEELS

The Duff-Norton hand wheel is for actuator customers who may require precise positioning, or may have loads which do not require motorized power to adjust.

NOTE

Hand wheels are not recommended for use with ball screw actuators as they contain no braking system. Also, for models with 12:1 ratios and lower, an additional locking mechanism to prevent back driving is recommended.

FEATURES

- Easy installation to existing actuators. All hand wheels are bored, keyed, and set-screw drilled to the proper dimensions.
- Revolving handle design for rotational ease.
- Recessed hub and spoke design.
- Cast iron material with chrome plating.



The table below presents dimensional information for all Duff-Norton Hand Wheels. To properly select the best hand wheel for your application, please review the provided information, or contact our customer service team.

Model Number	Capacity	Diameter	Width*	Bore Size	Keyway Size
HW04-.375	1/4 and 1/2 Ton MS and BS	4"	3-3/8"	0.375	1/8 x 1/16 x 1
HW06-.375	1/4 and 1/2 Ton MS and BS	6"	4"	0.375	1/8 x 1/16 x 1
HW04-.500	1 and 2 Ton MS and BS	4"	3-3/8"	0.500	1/8 x 1/16 x 1
HW06-.500	1 and 2 Ton MS and BS	6"	4"	0.500	1/8 x 1/16 x 1
HW04-.625	3 Ton MS and BS	4"	3-3/8"	0.625	3/16 x 3/32 x 1
HW06-.625	3 Ton MS and BS	6"	4"	0.625	3/16 x 3/32 x 1
HW06-.750	5 Ton MS and BS	6"	4"	0.750	3/16 x 3/32 x 1-1/4
HW08-.750	5 Ton MS and BS	8"	6-3/16"	0.750	3/16 x 3/32 x 1-1/4
HW10-.750	5 Ton MS and BS	10"	5-3/4"	0.750	3/16 x 3/32 x 1-1/4
HW08-1.00	10-20 Ton MS and BS	8"	6-3/16"	1.000	1/4 x 1/8 x 1-1/2
HW10-1.00	10-20 Ton MS and BS	10"	5-3/4"	1.000	1/4 x 1/8 x 1-1/2
HW12-1.00	10-20 Ton MS and BS	12"	6-1/2"	1.000	1/4 x 1/8 x 1-1/2

*From the end of the handle to the end of the hub